

We are IntechOpen, the world's leading publisher of Open Access books Built by scientists, for scientists

4,100

Open access books available

116,000

International authors and editors

120M

Downloads

Our authors are among the

154

Countries delivered to

TOP 1%

most cited scientists

12.2%

Contributors from top 500 universities



WEB OF SCIENCE™

Selection of our books indexed in the Book Citation Index
in Web of Science™ Core Collection (BKCI)

Interested in publishing with us?
Contact book.department@intechopen.com

Numbers displayed above are based on latest data collected.
For more information visit www.intechopen.com



Chapter

Maintenance Management with Application of Computational Intelligence Generating a Decision Support System for the Load Dispatch in Power Plants

Milton Fonseca Junior, Antônio Estanislau Sanches, Jandecy Cabral Leite, Jorge de Almeida Brito Júnior, Manoel Henrique Reis Nascimento, Carlos Alberto Oliveira de Freitas, Tirso Lorenzo Reyes Carvajal, David Barbosa de Alencar, Jorge Laureano Moya Rodriguez, Ubiratan Holanda Berzerra and Nadime Mustafa Moraes

Abstract

The development of a computational tool to support the decision of load dispatch according to the operational conditions of motors and generators of power plants is proposed, which are classified in relation to the probabilities of faults by a fuzzy system developed in this text, from indicators obtained from the analysis of lubricating oil, vibration analysis, and thermography of power generation equipment. The basis for the study is based on the principle of operation and operational conditions of the equipment to be dispatched for generation in a power plant, in addition to its particularities as specific consumption and the polluting emission for each equipment. In this way, this work aims not only to provide the tools to monitor these equipment but also, based on the management reports of vibration, temperature, and oil analysis, take corrective actions to maintain the necessary reliability and achieve the quality of the service through a preclearance procedure that takes into account the operating conditions of the equipment, obtaining performance indicators of the plan.

Keywords: economic load dispatch, management maintenance program, electric generators, power plants and fuzzy logic

1. Introduction

Most of the Brazilian thermoelectric park is completely shut down for months whenever the hydrological situation is favorable. As in the recent historical average

hydroelectric generation has been 90% of its generation capacity for the system [1], idleness has prevailed in the thermal park since the plants can only be activated when the hydroelectric reservoirs are below 50% of its maximum volume. The contrast with the international reality is striking. In most countries, power plants with combined cycle of coal or gas typically do not experience inactivity during a long time period. Instead, they operate at the base of the system, being dispatched almost continuously. Additionally, thermals that in other electrical systems are used for generation of tip, with daily activation or at least in good part of the working days, such as open or thermal cycle gas engines with motors, in Brazil, can remain idle for long because they are not necessary in normal or favorable hydrology situations.

On the other hand, it is necessary to ensure the supply of electricity to consumers within standards of continuity and reliability. Besides, the lack of investments in the industry causes the loss of product quality, and the excess of investments can make the value of the product very expensive, disheartening its wear [2, 3].

To guarantee the quality and reliability of the electric power supply, it is necessary to perform an optimal load dispatch [2, 4]. Too many papers presented in the literature develop the load dispatch of the thermal plants considering that all the engines of the plant have good technical conditions, but this is not always true, so in this chapter, a method is presented for the pre-dispatch of load that takes into account the technical state of the plant's motors through diagnosis and making use of fuzzy logic.

The development of a computational tool to support the decision of cargo dispatch according to the operating conditions of the engines and generators of thermal plants is proposed, which are classified in relation to the probabilities of failure by a fuzzy system developed in this thesis, from indicators obtained from lubricant oil analysis, vibration analysis, and thermography of power generation equipment. The basis for the study is based on the principle of operation and operational conditions of the equipment to be dispatched for generation in a thermal plant, besides its particularities as specific consumption and the quality of pollutant sent by each equipment.

2. Maintenance systems and their application in thermoelectric plants

The ability of a generation source to meet an energy demand can be influenced by unexpected units of power-generating units. The tests were even more advanced to repair preventive maintenance measures but were not revised in the 1990s with maintenance and maintenance work on engines and generators.

In recent times, condition-based maintenance (CBM) has been introduced in industrial systems to preventively maintain the right equipment at the right time relative to its current "operating condition." The good state of operation of a generator can be represented mainly by conventional indicators such as oil temperature, harmonic data, vibration, etc. Then the importance of monitoring the motors/generators and their diagnosis for the dispatch of cargo to not have unexpected interruptions.

Most energy generation unit scheduling packages are considered preventive maintenance schedules for units over an operational planning period of 1 or 2 years in order to defray the total operation while meeting the requirements of system power and maintenance restrictions. This problem consists of verifying the generating units must be stopped from production. The generating unit should be regularly examined for safety. It is important to detect a failure in a power generation unit that can be used in the machines. The main indication is a suitcase case response. Therefore, the fixation and the key point are used in the proposed methodology. The issue is addressed as an optimization problem. The model is developed by determining the objective function, which is a net power reserve of the unit [5].

They point out that condition-based maintenance (CBM) is an approach that gathers and assesses information in real time, and based on this information, it recommends maintenance decisions based on the existing condition of the system. In the last decades, research on CBM has been rising rapidly due to the increment of computer-enabled monitoring technologies. It has been proved that CBM, when it is planned carefully, can improve the reliability of equipment reducing costs [6].

The factor of diagnostic importance (DIF) is frequently used for choosing preferences in maintenance activities at power supply sections of distribution systems. In [7] approach to assess a weighted cumulative diagnostic importance factor (WCDIF) for each section, which represents a good parameter for the ordering of maintenance activities, is developed. The methodology includes the effects of distributed generation (DG) and the loads. It was implemented as case studies in two distribution systems, so that, in the end, sorting lists of feed sections for maintenance activities were obtained [7].

In order to improve the reliability and efficiency of equipment, it is very important to apply the condition-based maintenance (CBM). A good maintenance activity has a close relationship with security and diminishes costs, making this issue even more attractive to researchers [8].

Proper maintenance can increase the company's productivity and increase its value in the market. The main study provided a robust model that can evaluate strategically important available technology and may exclude outdated and/or inappropriate technology. There are many researches in this field in which the number of models has been proposed, such as the maintenance management system, maintenance performance measurement, and maintenance performance indicators, but the details of the effectiveness of the predictive maintenance indicator specifically based on maintenance and conditions (MBC) with maintenance and management requirements using the analytical hierarchy (AHP) process are hardly available in the literature [9].

Basically, the process consists of monitoring parameters that characterize the state of operation of the equipment. The methods employed involve techniques and procedures for measuring, monitoring, and analyzing these parameters [10]. It can be related as oil analysis, ferrography, thermography, and vibration analysis.

Motor operation data in conjunction with vibration, oil, and temperature analysis data are collected periodically at the plant and are used in an integrated way to feed a fuzzy rule-based system, which returns the pre-dispatch scheduling of the plant for the period of interest, taking into account the state of operation of the machines (**Figure 1**).

Thermal power plants involve many mechanical and electrical systems that require constant analyzing of power production. The data obtained through this analysis are necessary for a good operation, maintenance, and evaluation of the performance of the plants. For this analysis the so-called distributed control systems (DCS) are often used. Nevertheless, the obsolescence of this equipment increases the risks of unavailability of the generating units, mainly in thermoelectric plants, where mechanical wear is elevated, due to the high temperatures and the chemical agents used for the production of electric energy [11].

Mean time between failures (MTBF) or mean period between failures is a value assigned to a particular equipment to describe its reliability. This value indicates when a device failure may occur. When this index is high, the reliability of the equipment and, consequently, the maintenance will be also evaluated as excellent.

The average (MTTR) time for repair is a measure on the basis of repairable item maintenance. It represents the average time required to repair a component failure or mathematically expressed equipment, that is, corrective maintenance.

Oil analysis: The initial purpose of oil analysis of a lubricated assembly or a hydraulic system is to economize by optimizing the intervals between the exchanges. As the analyses carried out resulted in indicators that report on the wear

Pre-dispatch of Load in Thermolectric Power Plants Considering Maintenance Management by Fuzzy Logic

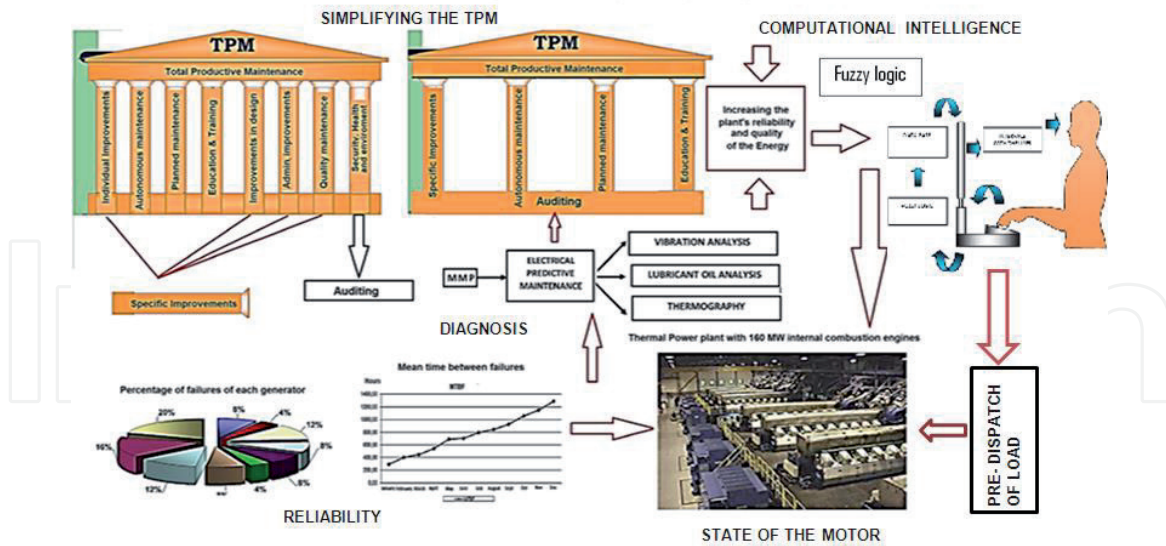

Figure 1. Methodology. Source: Authors.

of the lubricated components, the second objective of this process became defect control for predictive maintenance [12].

- In the upper left, you can see the simplification of the eight pillars of the TPM, for four pillars.
- The left-center part shows the diagnostic activities that allow to know the technical state of the motors, to know whether or not they can be used in the pre-dispatch of load.
- In the lower left, we show the reliability analyses, which together with the diagnosis allow us to know when it is possible for each motor to fail to consider it in the pre-dispatch of load.
- The right part shows the application of the fuzzy logic, to perform the pre-dispatch of load, according to the fuzzy rules that meet the technical state of the engines.

3. Fragments used for implant and end methodology TPM program

This chapter presents a new solution proposal, which includes the pre-dispatch of load focused on the operational conditions of the machines using computational tools, specifically fuzzy logic. This application incorporates some novelties, such as good maintenance management through TPM program for decision-making, including performance indicators of the generating units such as vibration, lubricating oil, and temperature, analyzing if the generating unit will operate and maintain reliability or will get into maintenance due to poorly diagnosed performance.

3.1 Pillar of specific improvements (recommended group: coordinators of ME, MA (plant managers), MP, and SMA)

Objective: To maximize the overall efficiency of the equipment and the operation through the analysis and elimination of operational losses (Table 1).

Pillar of specific improvements		Evaluation/progress/criteria
Evaluation/progress/criteria	Background/objective	Expected condition
1. Elaborate complete and detailed flow of the operation, identifying the various auxiliary engines and equipment, their respective priorities, and main risks. Note the current conditions so that you can compare after the improvements are implemented	To increase the knowledge of the whole operation and to standardize the knowledge of the participants of the working group, using the tools of quality	Working group formed, operational flow completed in a clear and didactic way, equipment, priorities, and main risks identified and being known by all participants
2. Identify the generation capacities in MW of each engine/plant—standard and real—and the current losses of the operation, quantifying through the Pareto chart	Identify the distortions between the actual and expected (standard or standard) of each engine/plant. Identify fuel and lubricant/engine/plant consumptions, knowing the performance of each one to be able to act on improvements	Motors, auxiliary equipment, and operations identified with their nominal and actual capacities Criterion to analyze and identify the main losses of the operation, stratify, and classify graphically in A, B, and C (Pareto)
3. Investigate losses in detail according to the priority grades I, II, and III of the chart, presenting alternatives for reducing or eliminating current losses found for later comparison	Allow to identify the fundamental causes of each selected loss, the actual operating conditions of each motor/auxiliary equipment (clearances, paint, leaks, instrumentation, working environment conditions, qualification of operators, necessary and available tools, etc.)	Use of the MASP tools to analyze and solve identified losses. PDCA, Fishbone, 5W2H Methodology being used to investigate and eliminate losses
4. Prepare detailed action plan for the chosen losses, and develop a schedule of activities, following the MASP methodology	Organize the various activities necessary to eliminate identified losses, in order of priority (from highest to lowest) and investment (from lowest to highest)	Plan of action prepared by the working group with actions, responsibility, deadlines, and progress of the activities chosen in the item above, through the MASP tools Put the action plan into practice, and compare the results before and after
5. Standardize operational procedures, ensuring that engines and auxiliary equipment are operated within the required conditions of pressure, temperature, speed, rpm, etc.	After achieving the expected results, standardize the procedures that should be followed by all operators	Interim operational standard completed and being used by the operators in each engine and auxiliary equipment
6. Analyze the existing operational reports, and make the necessary modifications to improve the quality of the annotated information, including maintenance stops by motor or auxiliary equipment, lack of spare parts, labor problems, transportation, etc.	Improving the quality of information to assist in the investigation of losses and their eliminations	Performance of the operation/ motor and auxiliary equipment being evaluated by comparing the indicators and objectives defined for each engine/plant. Information of the operational reports being provided with quality and accompanied by the managers, supervisors, and operators. No data distortion

Source: Authors.

Table 1.
Pillar of specific improvements.

3.2 Automatic maintenance pillar (recommended group: managers, supervisors, and operators of each plant)

Objective: To enable the operators to keep their workplaces clean and organized, inspecting their equipment, following operating procedures, lubricating and identifying abnormalities, and labeling and attempting to eliminate hard-to-reach places and sources of dirt (Table 2).

Automatic maintenance pillar		Valuation/progress/criteria
Evaluation/progress/criteria	Background/objective	Expected condition
1. Determine the procedure and how to identify abnormalities through labels. Determine labeling procedures, label types, and colors	Eliminate abnormalities of motors, auxiliary equipment, installations, workplace, and accumulated dirt, eliminate unused materials in the operation, visually identify the abnormal conditions that need to be repaired, and maintain the ideal working conditions that meet Industrial Safety. In this initial cleaning, the conditions of motors, auxiliary equipment, and installations such as loose bolts, lack of fixings and protections, damaged parts and temporary repairs, lack of signaling, etc., identified each with a label, and providing the necessary repairs must be observed. The label must only be removed after approval of the service performed	At initial cleaning, operators and personnel involved must be trained to identify abnormalities in motors, auxiliary equipment, facilities, and workplaces through stickers Areas, engines, auxiliary equipment, and facilities must be clean and maintained in this condition, no longer tolerating any signs of clutter and dirty locations. Use the 5S Locations that are not meeting this requirement should at least be flagged and their future repair be included in a timely, responsible action plan
2. Train participants to identify abnormalities of motors, auxiliary equipment and work area through labeling		
3. Perform initial cleaning on all motors, auxiliary equipment, and operating areas, determining ideal working conditions (no leakage, good flooring, motors, auxiliary equipment and facilities, painted and corrosion-free, with necessary signaling, conditions security, etc.)		
4. Prepare planning/schedule to carry out the necessary activities of removal of the labels placed in places that presented abnormalities	Monitor the activities performed, and measure the results after the improvements implemented	After label placement, a control should be created indicating the type of problem, the number of labels placed and removed, and the areas involved in the abnormalities, such as maintenance, operation, safety, and environment. Identification, simple, and objective control
5. Establish the basic conditions of engines, auxiliary equipment and facilities, workplaces, floors, walls, lighting, painting, signaling, temperatures, etc.	Ensure operation within the ideal standards required	Ideal conditions for motors, auxiliary equipment, signed installations, and work areas, with industrial safety colors, nameplates, lighting, and cleaning

Source: Authors

Table 2.
Automatic maintenance pillar.

3.3 Planned maintenance pillar (recommended group: PM coordinator, service managers and supervisors, and each plant)

Objective: To create a maintenance management corporate model for all engines and auxiliary equipment of the plants and external clients and to optimize interventions and reduce maintenance costs, ensuring the performance of auxiliary engines and equipment (Table 3).

3.4 Pillar of education and training (recommended group: this pillar is corporate and only depends on HR)

Objective: To support the other pillars, analyzing the qualification of participants and the need for training. Responsible for communication, TPM disclosure, event planning, and compliance with the basic program guidelines to facilitate documentation, reduction of dissemination costs, and support material (Table 4).

Planned maintenance pillar		Evaluation/progress
Evaluation/progress/criteria	Background/objective	Expected condition
1. Elaborate and approve methodology to prioritize engines, auxiliary equipment, and facilities in A, B, and C and disclose to all OPM coordinators. Determine form of identification and approve with the steering committee	Standardize how to prioritize engines, auxiliary equipment, and facilities as the company needs, with a focus on business	Complete prioritization worksheet containing pertinent questions from the areas involved in the operation (operation, maintenance, engineering, safety, and environment)
2. Determine how and when the meeting involving operation, engineering, maintenance, safety, and environment will be made to define all the engines, auxiliary equipment, and facilities of each plant in A, B, or C	Identify the company's business priorities to facilitate the deployment of a maintenance management model	Meeting to evaluate and classify in A, B, and C all engines, auxiliary equipment, and facilities of the company, marked or performed with the areas involved
3. After completion, visually list and identify priorities A, B, or C to facilitate supervision	Facilitate service and decision in the most appropriate action to be taken, according to priority	All motors, auxiliary equipment, and facilities, classified in A, B, and C with the visual identification labels, according to the model approved and adopted by the company
4. Identify the current state of each engine, auxiliary equipment, and installation, inspect/review, and make necessary repairs to maintain in perfect operational conditions	Rescue the ideal operating conditions of engines, auxiliary equipment, and facilities, improving availability, reliability, and maintenance	Inspection/revision planning in engines, equipment, and facilities A to redeem desired conditions Action plan defined with activities, materials, deadlines, time provided in each repair activity, and maintenance team
5. Elaborate the most indicated maintenance procedures for each engine, auxiliary equipment, and facilities, as recommended in the master plan Consider those in the technical manuals, MaMa2i, and create those that do not exist and are necessary	Define a maintenance philosophy to be used in equipment A, B, and C according to priority	Equipment A, B, and C classified and with the type and recommended maintenance plan completed

Planned maintenance pillar		Evaluation/progress
Evaluation/progress/criteria	Background/objective	Expected condition
6. Start the required activities for each engine, auxiliary equipment, and installation A. Follow the MaMa2i plan, and add non-existing services to the system	Organize maintenance, and update the data of each engine, auxiliary equipment, and installation A, creating history, technical inspection standards, and maintenance procedures Follow template created by engineers for reference	Planning and schedule of activities for engines, auxiliary equipment, and facilities A, completed and started

Source: Authors

Table 3.
Planned maintenance pillar.

Pillar of maintenance education and training		Evaluation/progress
Evaluation/progress/criteria	Background/objective	Expected condition
1. List all employees who have already been trained and those who require basic OPM training to participate in the work groups	Level the knowledge of all participants before starting to develop the activities in the working groups	All employees participating in the OPM program identified to receive the basic training provided by the pillar coordinators
2. Elaborate and make available in the network a basic training to minister to all the employees and in the integration of new ones	Standardize the material and information passed to employees	Teaching material for the basic training, completed, approved by the steering committee, and made available to the pillar coordinators
3. Determine the dates of the training of each pillar and the person in charge of ministering	Organize a schedule of activities to monitor, and audit the development of the TPM	Planning/schedule of training to be performed, indicating employees, dates, and instructors TPM training for integration of new employees, completed to be incorporated by HR
4. After the training, disseminate the number of participants to serve as an evaluation indicator of the pillar in the TPM program	To measure the degree of PMS development and to present the ET pillar indicators	Constant and updated dissemination of the number of employees trained and hours of training performed
5. Make competency map of all participants in the working groups, to identify the qualification, knowledge, and needs	Identify the need for training, planning, and implementation in order to allow the activities of the other OPM pillars to proceed	Worksheet of skills and qualification of the maintainers and operators completed, indicating the basic and specific training required
6. Elaborate internal/external training plan, one-point training, MASP, and lectures to adapt the knowledge need of each work group participant	Level the knowledge of the working group participants so they can take on other activities without any problem, according to the steps of the ME, MA, MP, and SMA pillars	Planning to carry out the training identified in the previous item, including lectures, one-point training, MASP, etc.

Source: Authors

Table 4.
Pillar of maintenance education and training.

Activity name	Responsibility	Check list
Check cleaning of areas	Plant manager	Check leaks, state of conservation, paint, and signage
Check the binder where the “cleaning pattern” of the area is located	Supervisors	Check if the cleaning pattern plug is placed in an easy to read location
Check if the tags are in control	Plant manager	Check in the label control software if there is any movement of placement of new labels
Check action plan to remove labels	Plant manager and supervisors	Check in the label control software if there is an action plan for removing the labels
Check signage of plants	Plant manager and supervisors	Check standardization of signaling
Check GPM frame of the plant	Engineering	Check if the information is up to date

Source: Authors.

Table 5.
 Check list pillar auditoria.

Members of the audit pillar checklist should meet monthly to discuss the MTBF goals and the monthly MTTR and other activities corresponding to the maintenance management program (Table 5).

4. Predictive maintenance using computational (fuzzy logic) decision support tool in preload dispatch

An application of fuzzy logic is justified by the ability to anticipate the possibilities of making the pre-dispatch time of the load on the operational tasks of the equipment.

This study deals with the application of fuzzy logic to load dispatch, but with a particularity that is to perform the said pre-dispatch of load taking into account the technical state of the engines, evaluated by different variables related to maintenance. In the first part, the development of the fuzzy rules and of the whole procedure of inference is exposed, and in the second part, all the tests evaluate the maintenance and the technical state of the motors. This tool served as the basis for the resolution of the real problem of pre-dispatch of cargo to satisfy the rationalized methods of just in time of the thermal plant on the operational conditions of the equipment (Figure 2).

A system based on fuzzy logic, as shown in Figure 2, can have its action schematized by the following constituent elements: fuzzifier; rules, or knowledge base; inference, or logical decision-making, and Defuzzifier [13].

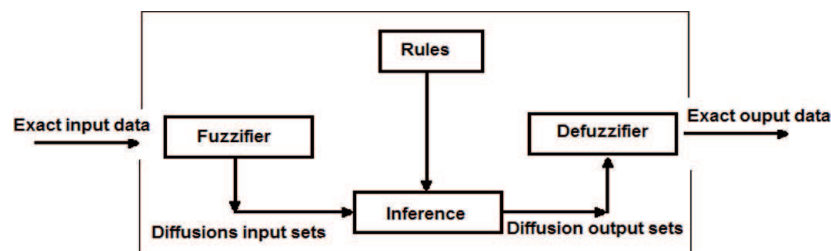

Figure 2.
 System based on fuzzy logic. Source: Authors.

In the first part the development of the fuzzy rules and of the whole procedure of inference is exposed and in the second part all the tests to evaluate the maintenance and the technical state of the motors. This tool served as the basis for the resolution of the real problem of pre-shipment of cargo to satisfy the rationalized methods of just in time of the thermal plant on the operational conditions of the equipment [14, 15].

The fuzzy system models the style of reasoning, imitating the capability to make decisions in an environment of uncertainty and imprecision. In this way, fuzzy logic is an intelligent technology, which provides a mechanism to manipulate imprecise information—concepts of small, high, good, very hot, cold—and that is able to infer an estimated answer to a question based on an inexact, incomplete knowledge, or not fully reliable information.

The development of a computational tool supports the load dispatch according to the location of motors and generators for thermal energy, analyzing the main thermoelectric generation variables for the entire predictive maintenance process.

All variables are inserted considering the intervals determined in the rules of inference as shown below.

The computational interface was useful for the search of some preselected characteristics to enable its implementation. **Tables 6–12** show such characteristics and respective purposes.

In this context, the following groups of information and data are abstracted: the input values, called crisp, the linguistic variables, and the fuzzy variables. The fuzzy logic is justified in the solution of this case study in function of the input variables with better representation in fuzzy sets. The variables due to the dimension of the universe of study were divided in 04 (three) and 03 (two) inputs and 01 (one) output, all independent of each other.

4.1 The input variable “vibration analysis”

For the determination of each variable, it was convenient to divide them into strips to approximate the actual situation to be checked. The calculation of these ranges on a scale according to **Tables 6–12** is shown below.

As the first level of variation, “vibration level” in **Tables 6** and **7**, let us consider better variable levels that were subdivided into four variables, normal, permissive, alert, and critical, each corresponding to the classification of vibration, velocity, and displacement levels measured in the equipment.

4.2 The input variable lubricating oil

The “level of analysis of the lubricating oil,” **Tables 8** and **9**, can be presented, for example, with the water content in the oil and solid and non-lubricated particle

Class	1-[N] Normal	2-[P] Permissible	3-[A] Alert	4-[C] Critical mm/s
(Class I)	(0.18–0.71)	(0.71–1.80)	(1.80–4.50)	(Above 4.50)
(Class II)	(0.18–1.10)	(1.10–2.80)	(2.80–7.10)	(Above 7.10)
(Class III)	(0.18–1.80)	(1.80–4.50)	(4.50–11.2)	(Above 11.2)
(Class IV)	(0.18–2.80)	(2.80–7.10)	(7.10–18.0)	(Above 18.0)
	A	B	C	D

Source: Authors

Table 6.
Manufacturer vibration levels.

Zone	Qualification	Operation of machines
Zone A	[N] Normal 0.18–2.80 mm/s	Commissioned machines should generally operate in this area
Zone B	[P] Permissible 2.80–7.10 mm/s	It is acceptable for unrestricted operation for long periods
Zone C	[A] Alert 7.10–18.0 mm/s	Unsatisfactory for continuous operations for long periods
Zone D	[C] Critical above 18.0 mm/s	It is sufficient to cause damage to the machine at any time

Source: Authors.

Table 7.
 Vibration severity rating relevance function.

Class	1-[N] Normal	2-[A] Alert	3-[C] Critical
(Water% volume)	(% ≤ 0.2)	(0.3)	(Above 03)
(Micron iron content)	(% ≤ 49)	(50)	(Above 51)
(Micron copper content)	(% ≤ 1)	(20)	(Above 21)
	A	B	C

Source: Authors.

Table 8.
 Lubricating oil.

Zone	Qualification	Operation of machines
A	[N] Normal	Commissioned machines should generally operate in this area
Water% volume	% ≤ 0.2	
Micron iron content	% ≤ 49	
Micron copper content	% ≤ 19	
B	[A] Alert	Unsatisfactory for continuous operations for long periods
Water% volume	0.3	
Micron iron content	50	
Micron copper content	20	
C	[C] Critical	It is sufficient to cause damage to the machine at any time
Water% volume	Above 0.3	
Micron iron content	Above 51	
Micron copper content	Above 21	

Source: Authors.

Table 9.
 Function of pertinence of the severity according to the oil.

content (iron and copper), the energy sources of the dispatch of load for generation of energy. The levels of analysis of the command type were subdivided into 03 (three) variables, correspondence and information quality [9].

(Zone)	(Thermography)	
(A)	([N] Normal less or equal 94.0 F)	
B	[P] Permissible	
(B/C)	(94.0 F)	(164.2 F)
C	[A] Alert	
(C/D)	(164.2 F)	(199.3 F)
(D)	[C] Critical above 199.3 F	

Source: Authors

Table 10.
Thermography to determine hot spots.

Zone	Qualification	Operation of machines
Zone A	[N] Normal ($T \leq 34.5^\circ\text{F}$)	Commissioned machines should generally operate in this area
Zone B	[P] Permissible ($34.5^\circ\text{F} < T \leq 73.5^\circ\text{F}$)	It is acceptable for unrestricted operation for long periods
Zone C	[A] Alert ($73.5^\circ\text{F} < T \leq 93^\circ\text{F}$)	Unsatisfactory for continuous operations for long periods
Zone D	[C] Critical ($T > 93^\circ\text{F}$)	It is sufficient to cause damage to the machine at any time

Source: Authors

Table 11.
Function of pertinence of the classification of thermography.

Motor technical status (ETM) for operating conditions		Operation of machines
Normal	76–100%	Commissioned machines should generally operate in this area
Permissible	51–75%	It is acceptable for unrestricted operation for long periods
Alert	26–50%	Unsatisfactory for continuous operations for long periods
Critical	0–25%	It is sufficient to cause damage to the machine at any time

Source: Authors.

Table 12.
Variable “engine technical status”.

4.3 The input variable “thermography analysis level”

Thermography analysis is an input variable, **Tables 10** and **11**, that can be used as a tool for load dispatching. The levels of thermographic analysis were just been subdivided in four (4) variables, each one corresponding to the dynamic memory. The use of images in thermal plants is very important for this reason. The infrared radiation is a base of studies on the thermal images, which has a function of capturing this radiation, interpreting and generating a quantitative image of the temperature of the studied body [16].

4.4 Output variable “technical condition of the motor”

The “estimated technical state of the engine (ETM)” is the output variable of the system, in relation to vibration (oil, water, iron, and copper). **Table 12** describes the

operating state of the generating units. The variable under study, as well as the variable “level,” was transferred to a percentage scale of 100% where “GREET” corresponds to the range of maximum values and the variable “BAD” corresponds to the range of minimum values up to zero. This value gives a greater range of possibilities, making the case study more precise.

5. Fuzzy simulation

The fuzzy inference with the input and output variables was performed employing the MATLAB version 8.0 tool and using a Mamdani model. This model adopts semantic rules for the processing of inferences and is commonly referred to as maximum-minimum inference. Such an inference model applies well to this type of problem since it uses union and intersection operations between sets. All variables are entered considering the intervals determined in the rules of inference. **Figure 3** shows the variables “vibration,” “water,” thermography, “iron,” and “copper” according to **Figure 3**.

All variables are entered considering the intervals determined in the rules of inference. **Figures 4–7** show the variables “vibration, water, thermography, iron, and copper” according to the figures below.

The first input variable is a thermography (**Figure 4**). According to **Tables 6** and **7**, we have

The second input variable is water (**Figure 5**) produced by the generating units. According to **Tables 8** and **9**, we have

The third input variable is the thermography (**Figure 6**) produced by the generating units. According to **Tables 10** and **11**, we have

The fourth input variable is iron (**Figure 7**) produced by the generating units. According to **Tables 8** and **9**, we have

The fifth input variable is copper (**Figure 8**) produced by the generating units. According to **Tables 8** and **9**, we have

The motor technical state is a product of the relationship between the input variable and output variable, which compose the pertinence functions expressed in the curves of **Figure 9**.

After editing the pertinence functions of all variables, the implemented rules are arranged in **Figure 10**, as shown in **Figure 8** for the visualization of the linguistic variables, thus forming antecedents and subsequent ones based on the Fuzzy inference rules.

To better understand the screen expressed, **Figure 11** shows all the possibilities that the simulation can produce. The movement of the red lines determines the other rule to be evaluated.

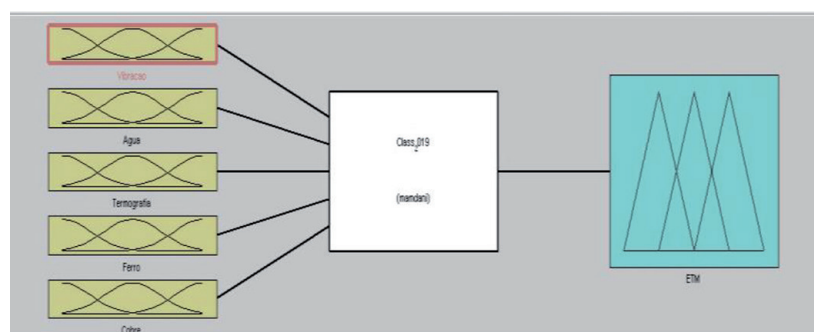

Figure 3. Mamdani's model. Source: Authors.

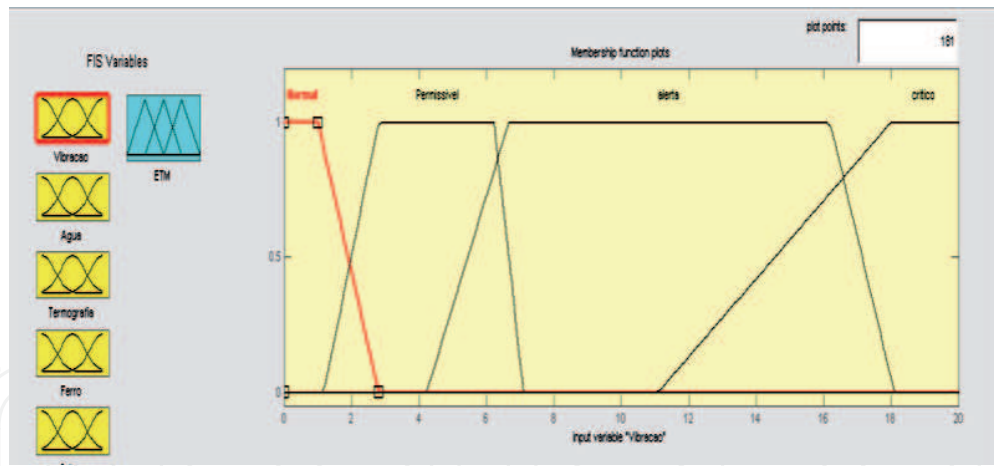

Figure 4.
"Vibration level." Source: Authors.

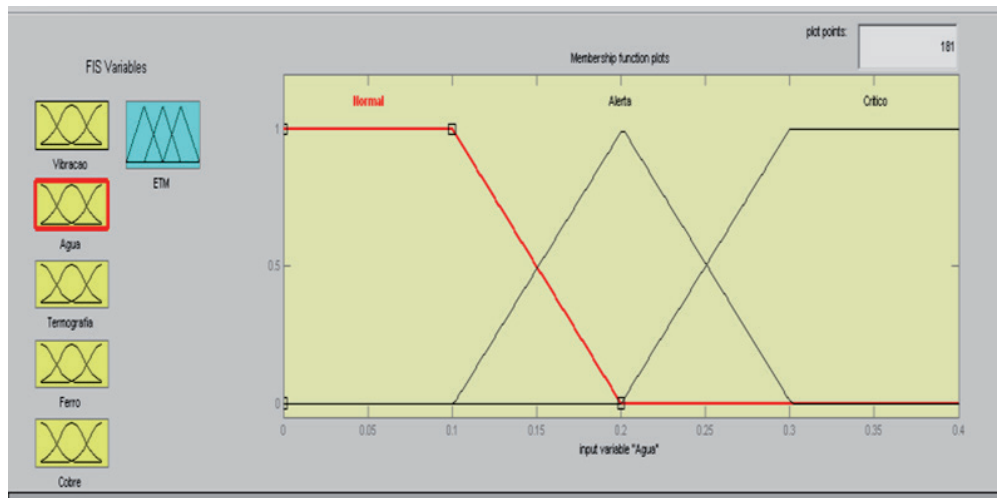

Figure 5.
"Water." Source: Authors.

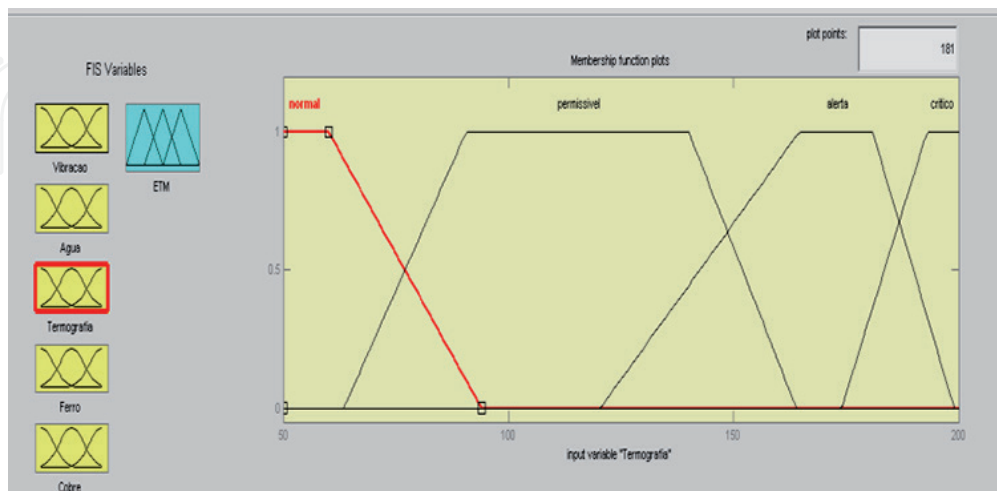

Figure 6.
"Thermography." Source: Authors.

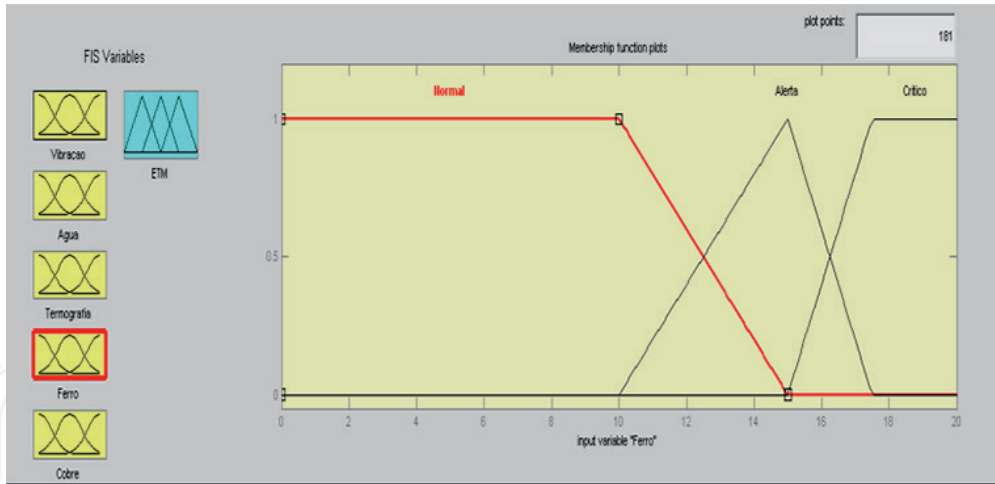

Figure 7.
"Copper." Source: Authors.

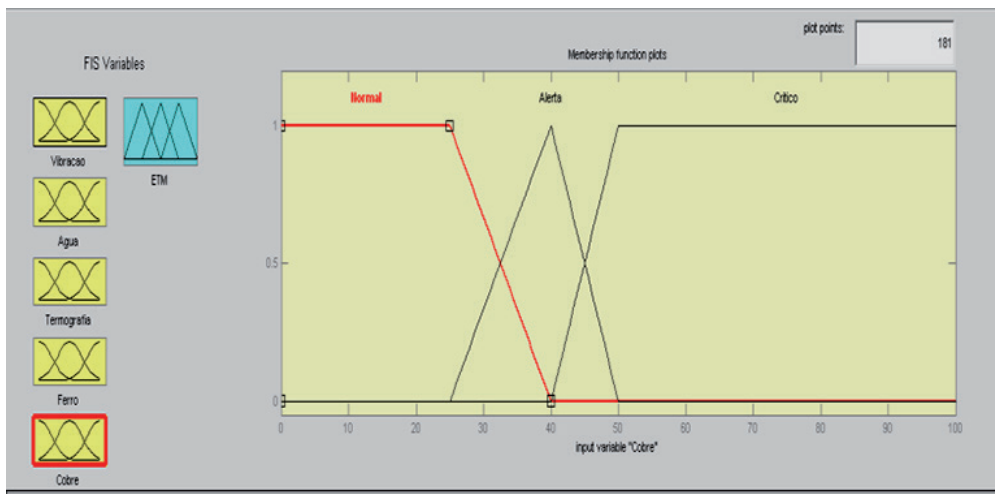

Figure 8.
"Copper." Source: Authors.

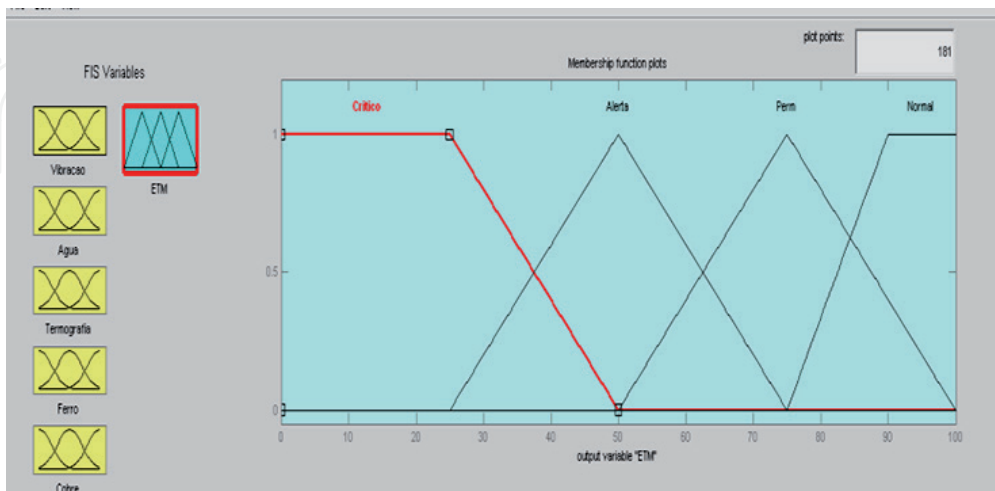

Figure 9.
Output variable: technical status. Source: Authors.

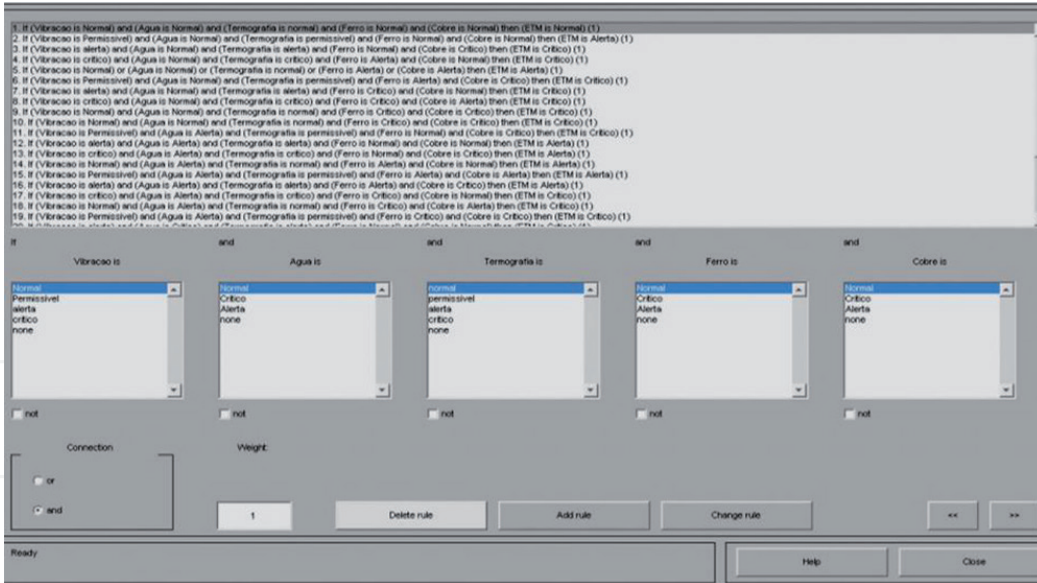

Figure 10. Implemented inference rules. Source: Authors.

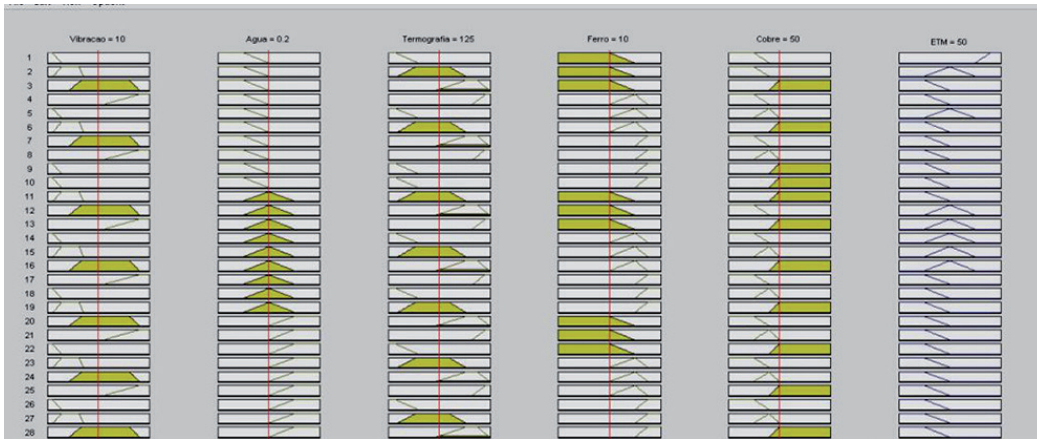

Figure 11. The input and output variables. Source: Authors.

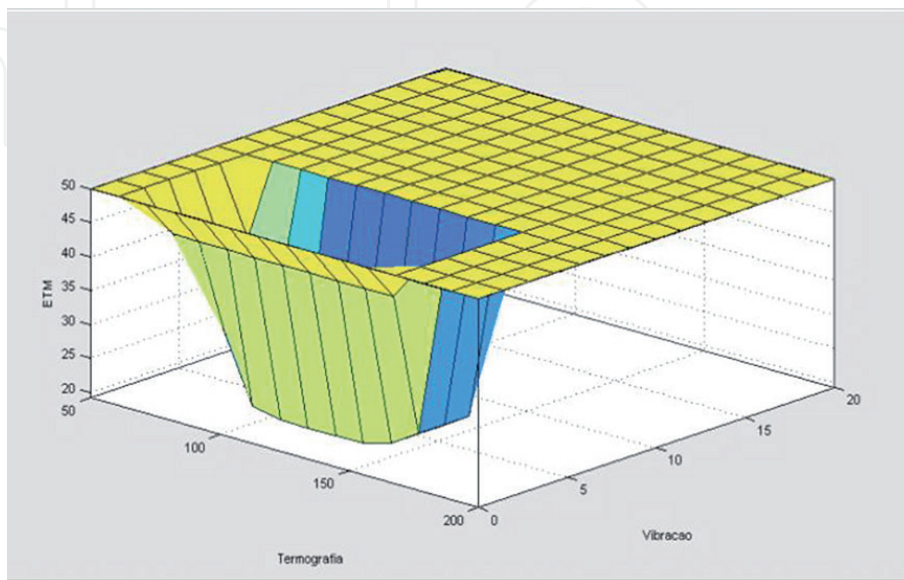

Figure 12. (Thermography × vibration). Source: Authors.

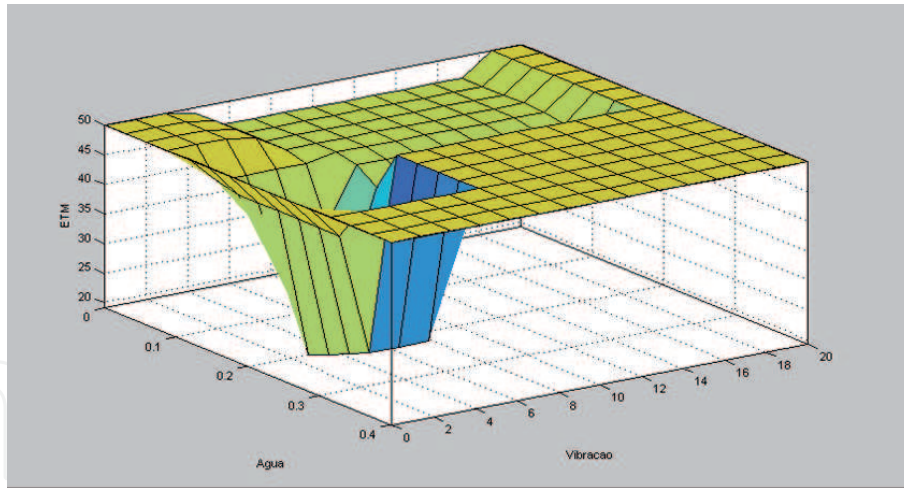

Figure 13.
(Water vs. vibration). Source: Authors.

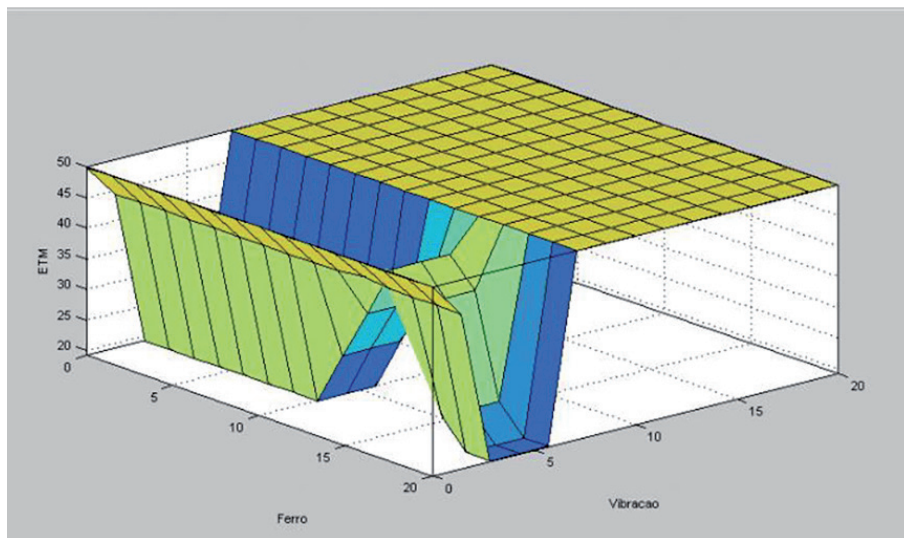

Figure 14.
(Iron × vibration). Source: Authors.

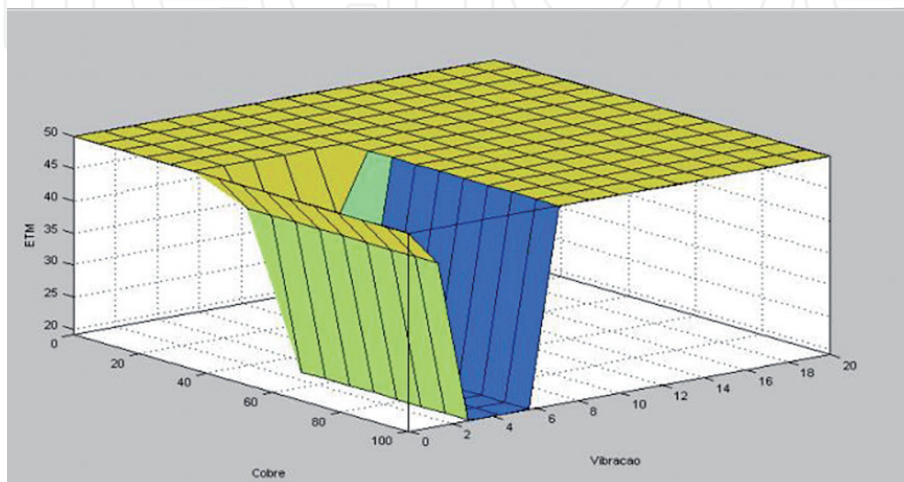

Figure 15.
(Copper vs. vibration). Source: Authors.

Figures 12–15 show the results of the inference rules from the 3D surface of the graph. In the blank, all the forms of execution are present that can exist within the simulation.

6. Case study (fuzzy logic with predictive maintenance).

6.1 Vibration analysis

Equipment status control is performed based on a calculated global value for the vibration signal measured at critical points on the machine surface. Since this value is due to a response signal from the structure to the dynamic excitation of the equipment operation, it represents a measure of the amplitude level of its vibration signal. In the case of the application for predictive maintenance, the international technical standards, among them the ISO, define two criteria for adoption of a global value (Figure 16).

6.2 Analysis of water content in lubricating oil

The determination of the presence and content of water in the case study was carried out through the distillation by drag. The sample is subjected to heating for distillation under controlled conditions, thus verifying the water content in the lubricating oil.

The graph shows the results of the analysis of water content, done periodically as predictive, showing normal levels, since the tolerable content is 0.3% (Figure 17).

6.2.1 Analysis of metal content in lubricating oil

The graph made by direct reading (iron and copper) ferrography, which was carried out based on the extraction of the magnetizable contaminant particles, is contained in the lubricant, through the action of a magnetic field (Figures 18 and 19).

6.3 Thermography

In addition to the use of the supervision system provided by the 9 FLUKE software, a thermovision is used, as shown in the figure, for measurement in low

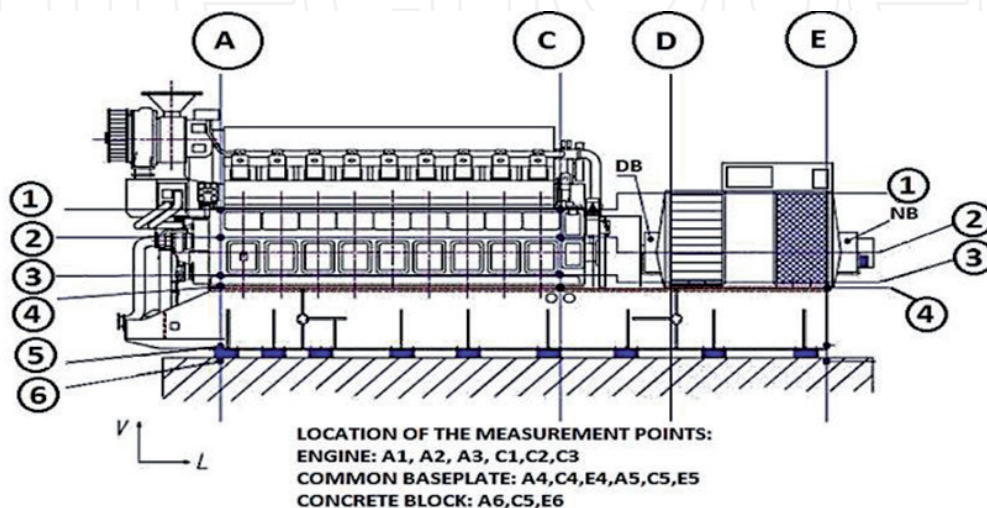

Figure 16.
 Measurement points in the vibration analysis. Source: Authors.

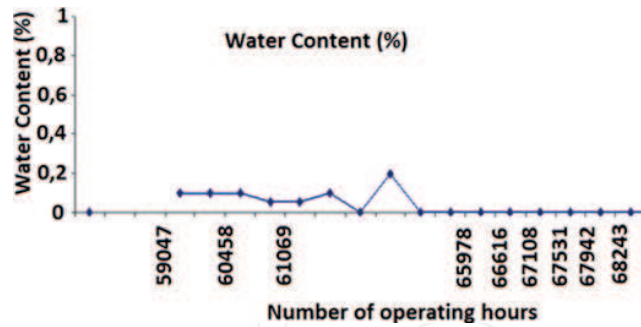

Figure 17.
 Water content and lubricating oil. Source: Authors.

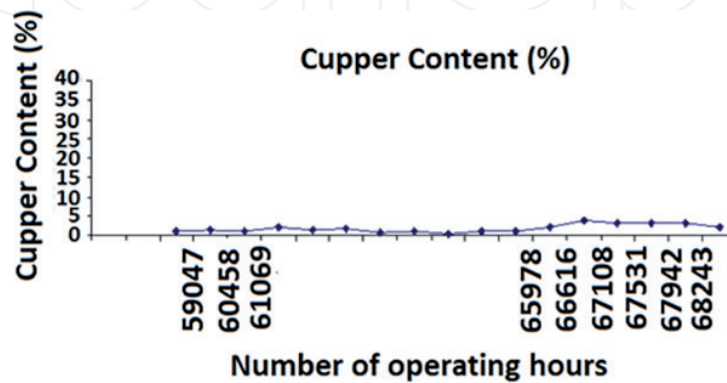

Figure 18.
 Copper content in the lubricating oil. Source: Authors.

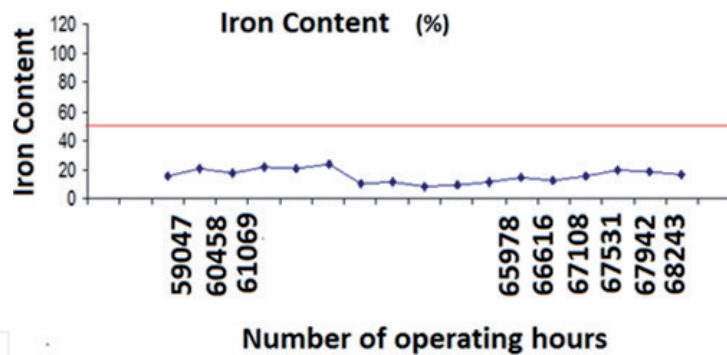

Figure 19.
 Iron content in the lubricating oil. Source: Authors.

or high voltage electrical systems, temperature variations caused by excess electric current in the furnace motor/generator 01 be with the hot spot and it will not be able to pre-dispatch cargo, **Figure 20**.

6.3.1. Fuzzy logic goes into the operating conditions of the equipment

In **Figure 21**, we can identify the anomalies likely to occur in the electric motor of generator 1 for all effects of temperature caused by excessive electric current. The heating screen of **Figure 22** indicates that the engine/generator 1 cannot be related for preloading under operating plants. Other motors and generators are in the normal comfort area (A) and can be classified for normal operation of the diffuse rule such as the motors and tuners 2, 3, 4, 5, 6, 7, 8, 9, and 10. 5 and 25 mark as normal operations without interruption and execution of restriction only for the motor/generator 1. Activate the excluded points in your electronic connection.

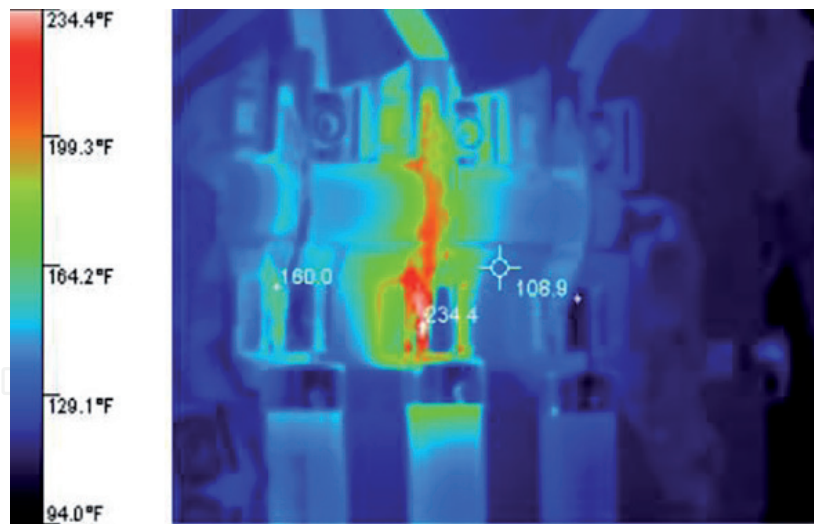

Figure 20.
Copper content in lubricating oil. Source: Authors.

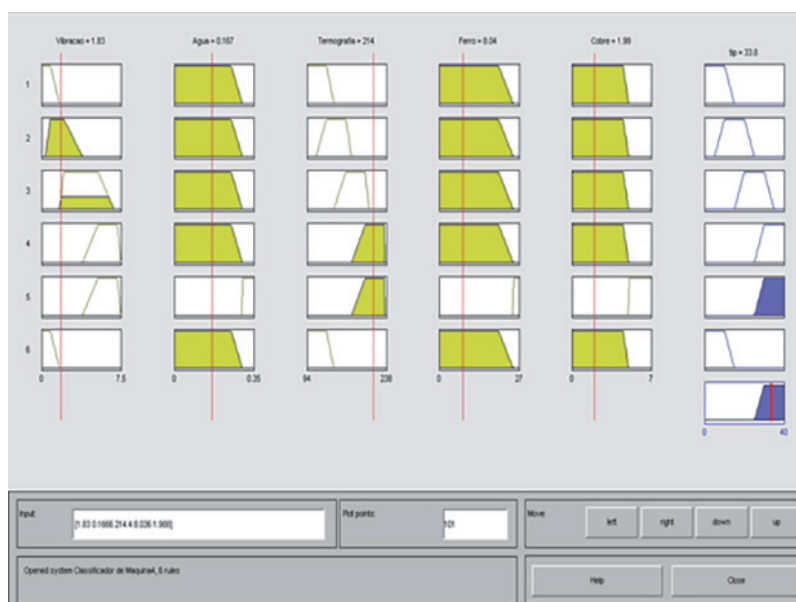

Figure 21.
Copper content in the lubricating oil. Source: Authors.

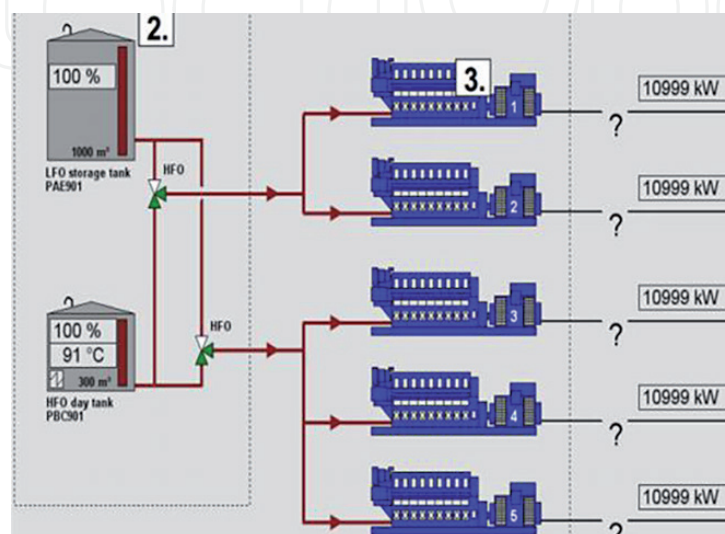

Figure 22.
Copper content in the lubricating oil. Source: Authors.

In **Figure 21** the parameters for the location of the equipment, according to the engine/generator 1, are not allowed to operate because they are not in good operating condition. The other engines and generators are located in area A (N) normal 2, 3, 4, 5, 6, 7, 8, 9, and 10 and are able to position themselves according to the needs of the organization. **Figure 22** informs which engines are conditional ideal for pre-shipment of cargo under operating conditions.

7. Results achieved

The objective of this work was to analyze the maintenance management system and its optimization through nebulous logic for the development of an intelligent system of support and decision-making for an ideal load dispatch demand.

The interface of the developed computational tool achieved the simplicity desired by the users themselves, as well as the ease of learning in their operation. According to the facts presented in this paper, it was possible to show that, currently, a predictive maintenance program and a total maintenance program are indispensable for large companies. This is to provide reliability to processes and equipment, detecting problems still in the initial phase. Programs of this type provide good maintenance planning for the maintenance industry. Thus, the company grows with regard to meeting deadlines, resulting in an increase in customer satisfaction.

In the present study, the gains from the two plans mentioned above could be assessed based on the information from the case study; we verified the reduction of corrective maintenance, and we verified the results with the increase of the MTBF and the decrease of the MTTR. The observed case can be implemented in any power generation machine that uses the fuel oil and, consequently, the use of oil stock, independent of the tank capacity and storage tank scales, which have only the standards of this system. The case study presented here can be implemented in any thermoelectric plant, independent of the loads to be dispatched, since the variables of this system are common to all.

Acknowledgements

The authors gratefully acknowledge the support of this research by FAPEAM, UFPA, ELETROBRAS, and ITEGAM.

IntechOpen

Author details

Milton Fonseca Junior^{1*}, Antônio Estanislau Sanches⁵, Jandecy Cabral Leite²,
Jorge de Almeida Brito Júnior², Manoel Henrique Reis Nascimento²,
Carlos Alberto Oliveira de Freitas², Tirso Lorenzo Reyes Carvajal²,
David Barbosa de Alencar², Jorge Laureano Moya Rodriguez³,
Ubiratan Holanda Berzerra⁴ and Nadime Mustafa Moraes⁵

1 Engineering Department, Generation of Mauá, Eletrobrás Amazonas GT,
Manaus, Amazonas, Brazil

2 Research Department, Institute of Technology and Education Galileo of the
Amazon (ITEGAM), Manaus, Amazonas, Brazil

3 Department of Post Graduate in Industrial Engineering, Federal University of
Bahia (UFBA), Brazil

4 Department of Post Graduate in Electric Engineering, Federal University of Pará
(UFPA), Brazil

5 University of the State of Amazon (UEA), Manaus, Amazonas, Brazil

*Address all correspondence to: milton.fonseca.jr@gmail.com

IntechOpen

© 2019 The Author(s). Licensee IntechOpen. This chapter is distributed under the terms of the Creative Commons Attribution License (<http://creativecommons.org/licenses/by/3.0>), which permits unrestricted use, distribution, and reproduction in any medium, provided the original work is properly cited. 

References

- [1] Silva SG. Sistema interligado nacional: análise das penalizações impostas às transmissoras com foco na aplicação da parcela variável. Dissertação (Mestrado em Ciências)-Universidade Federal de Uberlândia, Uberlândia. 2016. p. 122
- [2] Ma H et al. Multi-objective biogeography-based optimization for dynamic economic emission load dispatch considering plug-in electric vehicles charging. *Energy*. 2017;**135**: 101-111. ISSN 0360-5442
- [3] Pless J, Fell H. Bribes, bureaucracies, and blackouts: Towards understanding how corruption at the firm level impacts electricity reliability. *Resource and Energy Economics*. 2017;**47**:36-55. ISSN 0928-7655
- [4] Kumar N. A non convex cost function based optimal load dispatch using tlbo algorithm. *Journal of Engineering Science & Technology Review*. 2017;**10**(1). ISSN 1791-2377
- [5] Alam N et al. A 0/1 mixed integer linear programming approach to establish an effective preventive maintenance policy for power plant. *International Journal of Industrial and Systems Engineering*. 2017;**25**(4):478-498
- [6] Alaswad S, Xiang Y. A review on condition-based maintenance optimization models for stochastically deteriorating system. *Reliability Engineering & System Safety*. 2017;**157**:54-63
- [7] Arya R. Ranking of feeder sections of distribution systems for maintenance prioritization accounting distributed generations and loads using diagnostic importance factor (DIF). *International Journal of Electrical Power & Energy Systems*. 2016;**74**:70-77
- [8] Azadeh A, Asadzadeh SM, Salehi N, Firoozi M. Condition-based maintenance effectiveness for series-parallel power generation system—A combined Markovian simulation model. *Reliability Engineering & System Safety*. 2015;**142**:357-368
- [9] Baidya R, Ghosh SK. Model for a predictive maintenance system effectiveness using the analytical hierarchy process as analytical tool. *IFAC-PapersOnLine*. 2015;**48**(3):1463-1468
- [10] Ripper is a 2001 Canadian-British horror film, directed by John Eyres. The film stars A. J. Cook and Bruce Payne. It was written and produced by John A. Curtis
- [11] Fonseca, Miltonx, et al. Pre-dispatch of load in thermoelectric power plants considering maintenance management using fuzzy logic. *IEEE Access*. 2018;**6**:41379-41390
- [12] Junior MF et al. Maintenance tools applied to electric generators to improve energy efficiency and power quality of thermoelectric power plants. *Energies*. 2017;**10**(8):1091
- [13] Larguech S et al. Fuzzy sliding mode control for turbocharged diesel engine. *Journal of Dynamic Systems, Measurement, and Control*. 2016;**138**(1):011009. ISSN 0022-0434
- [14] Gonçalves BP et al. Avaliação de impactos harmônicos na rede elétrica através dos indicadores THD e fator de potência utilizando lógica fuzzy. *Revista Brasileira de Energia*. 2013;**19**(1):9-27
- [15] Nogueira EL, Nascimento MHR. Inventory control applying sales demand prevision based on fuzzy inference system. *ITEGAM-Journal of Engineering and Technology for Industrial Applications (ITEGAM-JETIA)*. 2017;**3**:31-36. DOI: 10.5935/2447-0228.20170060

[16] López-Pérez D, Antonino-Daviu J. Application of infrared thermography to failure detection in industrial induction motors: Case stories. IEEE Transactions on Industry Applications. 2017;53(3):1901-1908

IntechOpen

IntechOpen